

K-B Axle has produced trailer axles and related automotive products since 1932.

Our experience assures you of the finest quality commercial axles.

This catalog covers our heavy duty trailer axles, spindle assemblies and components for off-highway and special applications.

For axles and components with capacities greater than 75,000 pounds, please contact us for pricing and availability.



TABLE OF CONTENTS

K-B Axle Co.

5775 NW WAGON WAY / HILLSBORO, OR 97124-8531 / ph: 866.531.0600 / fx: 503.531.0601

COMPLETE AXLE ASSEMBLIES

T37	40,000 Pound Capacity	2
S54	60,000 Pound Capacity	4
S55	60,000 Pound Capacity	6
S65	75,000 Pound Capacity	8

REPLACEMENT PARTS

Brake Shoes	10
Brake Anchors	10
Spindle Nuts and Washers	10
Brake Shoe Anchor Pins	10
Camshaft Springs	11
Brake Shoe Return Springs	11
Brake Shoe Rollers and Pins	11
Bushings	11
Camshaft and Camshaft Housings	12
Hub Caps and Hub Cap Gaskets	12
Grease Retainers and Rings	12
Air Chamber Brackets	13
Air Chambers	13
Slack Adjusters	13
Hubs	14
Spoke Wheels	15
Disc Wheel and Rim Holding Components	16
Brake Drums	17
Spacer Bands	17
Wedge Bands	17

MISCELLANEOUS HARDWARE	18
------------------------	----

TIRE INFORMATION GUIDE	19
------------------------	----

AXLE INFORMATION FORM	20
-----------------------	----

T37 SERIES AXLE

K-B Axle Co.

40,000 POUND CAPACITY

5775 NW WAGON WAY / HILLSBORO, OR 97124-8531 / ph: 866.531.0600 / fx: 503.531.0601

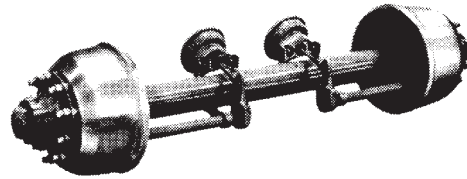
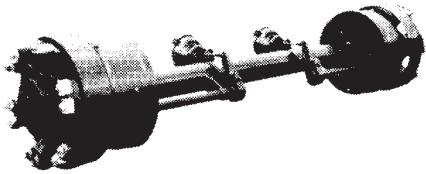

Approx. WT. 1778 lbs.

Approx. WT. 1373 lbs.

AXLE BEAM 6" O.D. – Heat-treated tubular steel with inserted spindles.

BEARINGS		Cone	Cup
Inner		861	854
Outer		740	742

HUBS 10 stud, 13³/₁₆" B.C.

Steel spoke wheels for dual demountable 12 x 24 or 12 x 25 tires.

BRAKES 20" x 8" x 3/4" FMS 4350 - Other brake sizes available. Contact factory indicating requirements.

FEATURES

- ▶ Completely enclosed camshafts seal dirt out and grease in.
- ▶ Individual, positively locked brake shoe anchor pins for positive, permanent alignment.
- ▶ Brake shoes are of all-steel construction with replaceable bushings.
- ▶ Heat-treated steel insert spindles combine utmost strength with light weight.
- ▶ Hubs engineered to meet the most severe operating conditions.

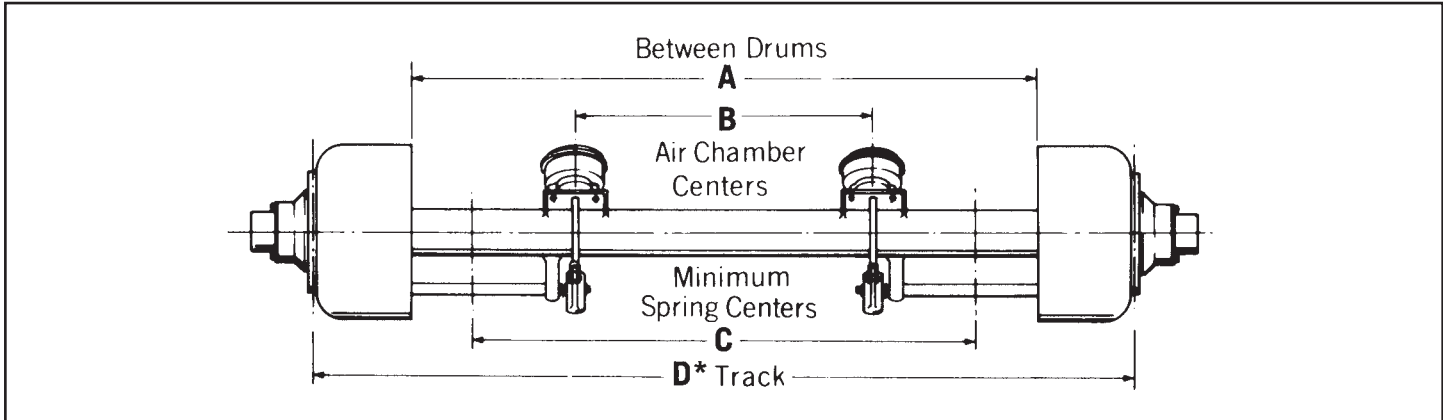

Model No.	Mechanical Air Brake Size	Hub Type	A	B	C	D*	Tire Size	Wheel Size	Width Incl. Tires	Camshaft Length
T37	No Brake	10 Stud 13 ³ / ₁₆ B.C.	–	–	39	82	12 x 24	24 - 8.5	} 108	26 ¹ / ₂
T37	20 x 8		56 ¹ / ₂	16 ¹ / ₂	39	82	12 x 25	25 - 8.5		
T37	20 x 8	Spoke Wheels for Dual Demountable Tires	58	17 ¹ / ₂	39	82	14 x 25	25 - 10	113 ¹ / ₂	

Note: Specify Brake Size and Hub Type when ordering axle assemblies.

* Other Track Widths and Camshaft Lengths are available on request.



T37 SERIES AXLE

40,000 POUND CAPACITY

THESE PARTS PERTAIN TO 10-STUD AXLES ONLY

Brake Size	Hub Type	Hub Part No.	Brake Shoe Part No.	Brake Block FMS No.	Brake Drum Part No.
20 x 8 Mech.	10 Stud Budd 13 $\frac{3}{16}$ " B.C. 1 $\frac{5}{16}$ " Studs	KB-5944	KB-6501	4350	6U-20-9

Contact factory for parts list for dual cam brake axle. Furnish model number and date of manufacture.
Banded brake drums available. Add 'B' to brake drum part number when ordering.

Description	Part Number	Description	Part Number
Axle Beam (specify track)	C-9874	Grease Retainer	E-10708
Air Chamber Type 36	213	Grease Retainer Ring	E-7642
Air Chamber Bracket	KB-5155-E	Hub Cap	D-8025
Air Chamber Bracket Washer	E-11168	Hub Cap Gasket	E-8661
Anchor	KB-6502	Hub Cap Bolt	14015
Anchor Pin	E-11046	Hub Cap Lockwasher	11004
Anchor Pin Lock	13305	Slack Adjuster	14308
Anchor Pin Grease Fitting	9801	Spindle Nut	KB-3987
Anchor Bolt	14011	Spindle Nut D-Washer	E-4450
Anchor Bolt Lockwasher	11005	Spindle Nut Cotter Pin	8903
Anchor Bolt Nut	11247	Wheel Stud R.H.*	15442
Brake Shoe Bushing	E-11051	Wheel Stud L.H.*	15443
Brake Shoe Roller	E-11219	Wheel Nut R.H. (inner)*	11236
Brake Shoe Roller Pin	E-11220	Wheel Nut L.H. (inner)*	11237
Brake Shoe Roller Pin Lock	E-10231	Wheel Nut R.H. (outer)*	11238
Brake Return Spring	D-8689	Wheel Nut L.H. (outer)*	11239
Brake Block Bolt	14026	1" Back Nut*	E-11215
Brake Block Bolt Lockwasher	11004	Parts for Assembly with Spoke Wheels	
Brake Block Bolt Nut	11265	Wheel and Drum Attaching Bolt	14017
Camshaft Seal	E-11226	Wheel and Drum Attaching Lockwasher	11006
Camshaft Washer	E-11221	Wheel and Drum Attaching Nut	11260
Camshaft Spring	E-11222	Wheel Stud	15401
Camshaft Retaining Washer	E-11223	Wheel Rim Clamp	8305
Camshaft Retaining Bolt	14025	Wheel Clamp Nut	11201
Camshaft Lockwasher	11004	Heavy Duty Spacer Band	C-11140
Camshaft Housing Grease Fitting	9803	(Use $\frac{3}{4}$ " Hardened Washer on Spoke Wheels)	

STANDARD PRODUCTION 1 $\frac{3}{4}$ " DIAMETER CAMSHAFTS AND HOUSINGS

Camshaft Number	Overall Length	Housing Number
P-6497 B – P-6498 B	24 $\frac{1}{4}$ "	D-11225-2
P-6499 B – P-6500 B	26 $\frac{1}{2}$ "	D-11225-3
P-6508 B – P-6509 B	29 $\frac{1}{2}$ "	D-11225-5

SPECIAL LENGTH CAMSHAFTS AVAILABLE AT EXTRA CHARGE.

Note: Furnish axle model or serial number when ordering replacement parts.
* Not needed in axle with spoke wheel. Single wheel studs and nuts available upon request.
Due to design of the 10-stud drum, clearance is not sufficient to allow for hardened washer.

S54 SERIES AXLE

60,000 POUND CAPACITY

K-B Axle Co.

5775 NW WAGON WAY / HILLSBORO, OR 97124-8531 / ph: 866.531.0600 / fx: 503.531.0601

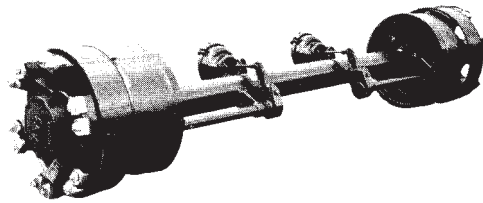

Approx. WT. 2230 lbs.

AXLE BEAM 6" O.D. Solid Steel
Heat-treated 4140

BEARINGS	Cone	Cup
Inner	938	932
Outer	936	932

HUBS Steel spoke wheels for dual demountable 14 x 24 or 14 x 25 tires.

BRAKES 20" x 8" x 3/4" FMS 4350 – Other brake sizes available for special application. Contact factory indicating requirements.

FEATURES

- ▶ Completely enclosed camshafts seal dirt out and grease in.
- ▶ Individual, positively locked brake shoe anchor pins for positive, permanent alignment.
- ▶ Brake shoes are of all-steel construction with replaceable bushings.
- ▶ Wheels engineered to meet the most severe operating conditions.

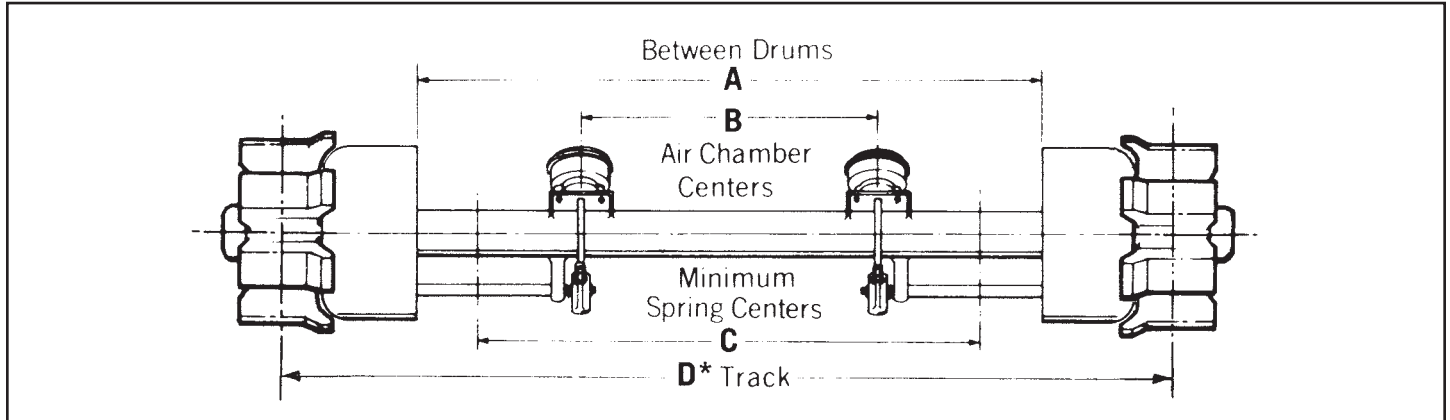

Model No.	Mechanical Air Brake Size	A	B	C	D*	Tire Size	Rim Size	Width Incl. Tires	Camshaft Length
S54	No Brake	—	—	40	90	14 x 24	24 - 10	123 1/2"	26 1/2"
	20 x 8	62 3/8"	22	40	90	14 x 25	25 - 10	123"	

Note: Specify Brake Size and Hub Type when ordering axle assemblies.

* Other Track Widths and Camshaft Lengths are available on request.



S54 SERIES AXLE

60,000 POUND CAPACITY

Brake Size	Hub Type	Wheel Part No.	Brake Shoe Part No.	Brake Block FMS No.	Brake Drum Part No.
20 x 8	Steel Spoke Wheel	KB-6453	KB-6501	4350	6U-20-8

Contact factory for parts list for dual cam brake axle. Furnish model number and date of manufacture.
Banded brake drums available. Add 'B' to brake drum part number when ordering.

Description	Part Number	Description	Part Number
Axle Beam (specify track)	C-10754	Camshaft Lockwasher	11004
Air Chamber Type 36	213	Camshaft Housing Grease Fitting	9803
Air Chamber Bracket	KB-5155-E	Grease Retainer	E-11066
Air Chamber Bracket Washer	E-11168	Grease Retainer Ring	E-7704
Anchor	KB-6502	Hub Cap	KB-3976
Anchor Pin	E-11046	Hub Cap Gasket	D-5747
Anchor Pin Lock	13305	Hub Cap Bolt	14006
Anchor Pin Grease Fitting	9801	Hub Cap Lockwasher	11004
Anchor Bolt	14011	Slack Adjuster	14308
Anchor Bolt Lockwasher	11005	Spindle Nut	KB-5463
Anchor Bolt Nut	11247	Spindle D Washer	D-5164
Brake Shoe Bushing	E-11051	Spindle Nut Cotter Pin	8903
Brake Shoe Roller	E-11219	Wheel and Drum Attaching Bolt	14017
Brake Shoe Roller Pin	E-11220	1" Hardened Washer	15821
Brake Shoe Roller Pin Lock	E-10231	Wheel and Drum Attaching Lockwasher	11006
Brake Return Spring	D-8689	Wheel and Drum Attaching Nut	11260
Brake Block Bolt	14026	Wheel Stud	15401
Brake Block Bolt Lockwasher	11004	Wheel Rim Clamp	8305
Brake Block Bolt Nut	11265	Wheel Camp Nut	11201
Camshaft Washer	E-11221	Heavy Duty Spacer Band	C-11140
Camshaft Seal	E-11226		
Camshaft Spring	E-11222		
Camshaft Retaining Washer	E-11223		
Camshaft Retaining Bolt	14025		

STANDARD PRODUCTION 1¾" DIAMETER CAMSHAFTS AND HOUSINGS

Camshaft Number	Overall Length	Housing Number
P-6497 B – P-6498 B	24¼"	D-11225-2
P-6499 B – P-6500 B	26½"	D-11225-3
P-6508 B – P-6509 B	29½"	D-11225-5

SPECIAL LENGTH CAMSHAFTS AVAILABLE AT EXTRA CHARGE.

Note: Furnish axle model or serial number when ordering replacement parts.

S55 SERIES AXLE

60,000 POUND CAPACITY

K-B Axle Co.

5775 NW WAGON WAY / HILLSBORO, OR 97124-8531 / ph: 866.531.0600 / fx: 503.531.0601

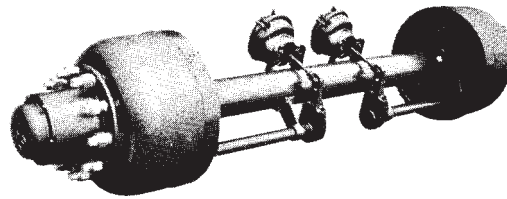

Approx. WT. 1945 lbs.

AXLE BEAM 6" O.D. Solid Steel
Heat-treated 4140

BEARINGS		Cone	Cup
Inner		938	932
Outer		861	854

HUBS 10 stud, 13³/₁₆" B.C. with ¹⁵/₁₆" studs.

BRAKES 20" x 8" x ³/₄" FMS 4350 – Other brake sizes available for special application. Contact factory indicating requirements.

FEATURES

- ▶ Completely enclosed camshafts seal dirt out and grease in.
- ▶ Individual, positively locked brake shoe anchor pins for positive, permanent alignment.
- ▶ Brake shoes are of all-steel construction with replaceable bushings.
- ▶ Wheels engineered to meet the most severe operating conditions.

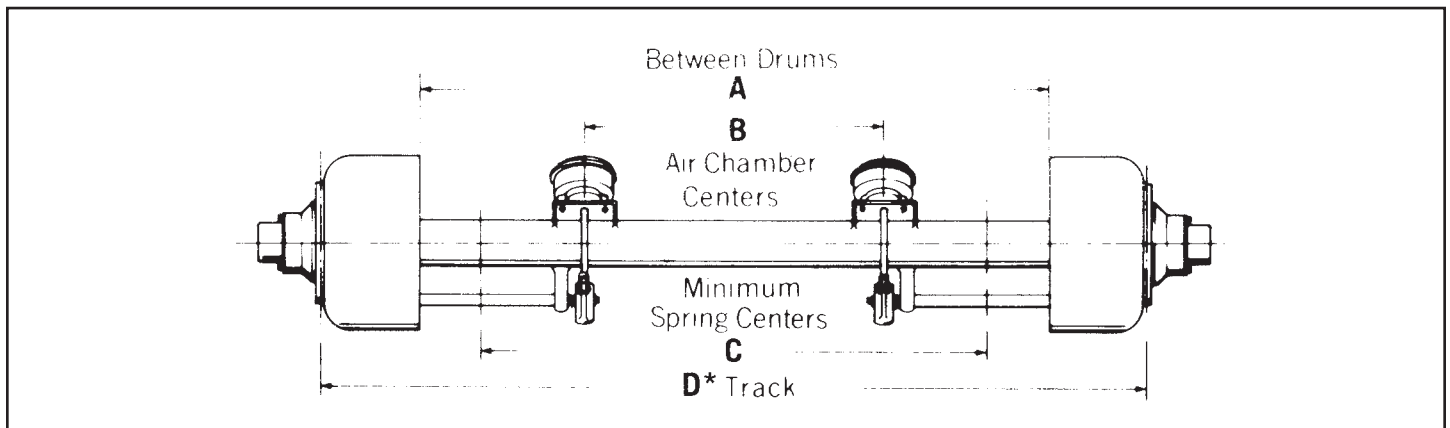

Model No.	Mechanical Air Brake Size	A	B	C	D*	Tire Size	Rim Size	Width Incl. Tires	Camshaft Length
S55	No Brake	—	—	40	90	14 x 24	24 - 10	123"	26 ¹ / ₂ "
S55	20 x 8	60 ⁷ / ₈	20 ¹ / ₂	40	90	14 x 25	25 - 10		

Note: Specify Brake Size and Hub Type when ordering axle assemblies.
* Other Track Widths and Camshaft Lengths are available on request.



S55 SERIES AXLE

60,000 POUND CAPACITY

Brake Size	Hub Type	Hub Part No.	Brake Shoe Part No.	Brake Block FMS No.	Brake Drum Part No.
20 x 8	10 Stud Budd 13 ³ / ₁₆ " B.C. 1 ⁵ / ₁₆ " Studs	KB-5947-1	KB-6501	4350	7U-20-1

Contact factory for parts list for dual cam brake axle. Furnish model number and date of manufacture.
Banded brake drums available. Add 'B' to brake drum part number when ordering.

Description	Part Number	Description	Part Number
Axle Beam (specify track)	C-9965	Grease Retainer	E-10893
Air Chamber Type 36	213	Grease Retainer Ring	E-7704
Air Chamber Bracket	KB-5155-E	Hub Cap	KB-5979
Air Chamber Bracket Washer	E-11168	Hub Cap Gasket	E-10135
Anchor	KB-6502	Hub Cap Bolt	14006
Anchor Pin	E-11046	Hub Cap Lockwasher	11004
Anchor Pin Lock	13305	Slack Adjuster	14308
Anchor Pin Grease Fitting	9801	Spindle Nut	KB-5631
Anchor Bolt	14011	Spindle D Washer	E-9519
Anchor Bolt Lockwasher	11005	Spindle Nut Locking Bolt	2304
Anchor Bolt Nut	11247	Spindle Nut Locking Nut	11280
Brake Shoe Bushing	E-11051	Spindle Nut Locking Washer	11008
Brake Shoe Roller	E-11219	Wheel Studs R.H.	15435
Brake Shoe Roller Pin	E-11220	Wheel Studs L.H.	15436
Brake Shoe Roller Pin Lock	E-10231	Wheel Stud Nuts	11227
Brake Return Spring	D-8689	Wheel Stud Flat Washer	15821
Brake Block Bolt	14026	Wheel Nuts R.H. (inner)	11236
Brake Block Bolt Lockwasher	11004	Wheel Nuts L.H. (inner)	11237
Brake Block Bolt Nut	11265	Wheel Nuts R.H. (outer)	11238
Camshaft Washer	E-11221	Wheel Nuts L.H. (outer)	11239
Camshaft Seal	E-11226	Single wheel studs and nuts available on request.	
Camshaft Spring	E-11222		
Camshaft Retaining Washer	E-11223		
Camshaft Retaining Bolt	14025		
Camshaft Lockwasher	11004		
Camshaft Housing Grease Fitting	9803		

STANDARD PRODUCTION 1³/₄" DIAMETER CAMSHAFTS AND HOUSINGS

Camshaft Number	Overall Length	Housing Number
P-6497 B – P-6498 B	24 ¹ / ₄ "	D-11225-2
P-6499 B – P-6500 B	26 ¹ / ₂ "	D-11225-3
P-6508 B – P-6509 B	29 ¹ / ₂ "	D-11225-5

SPECIAL LENGTH CAMSHAFTS AVAILABLE AT EXTRA CHARGE.

Note: Furnish axle model or serial number when ordering replacement parts.

S65 SERIES AXLE

75,000 POUND CAPACITY

K-B Axle Co.

5775 NW WAGON WAY / HILLSBORO, OR 97124-8531 / ph: 866.531.0600 / fx: 503.531.0601

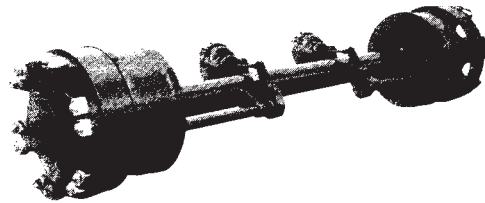

Approx. WT. 2690 lbs.

AXLE BEAM 6½" O.D. Solid Steel
Heat-treated 4140

BEARINGS	Cone	Cup
Inner	95525	95925
Outer	67390	67322

HUBS Steel spoke wheels for dual demountable 16 x 25 or 18 x 25 tires.
12 stud, 15" B.C. hubs also available.

BRAKES 20" x 8" x ¾" FMS 4350 – Other brake sizes available for special application. Contact factory indicating requirements.

FEATURES

- ▶ Completely enclosed camshafts seal dirt out and grease in.
- ▶ Individual, positively locked brake shoe anchor pins for positive, permanent alignment.
- ▶ Brake shoes are of all-steel construction with replaceable bushings.
- ▶ Wheels engineered to meet the most severe operating conditions.

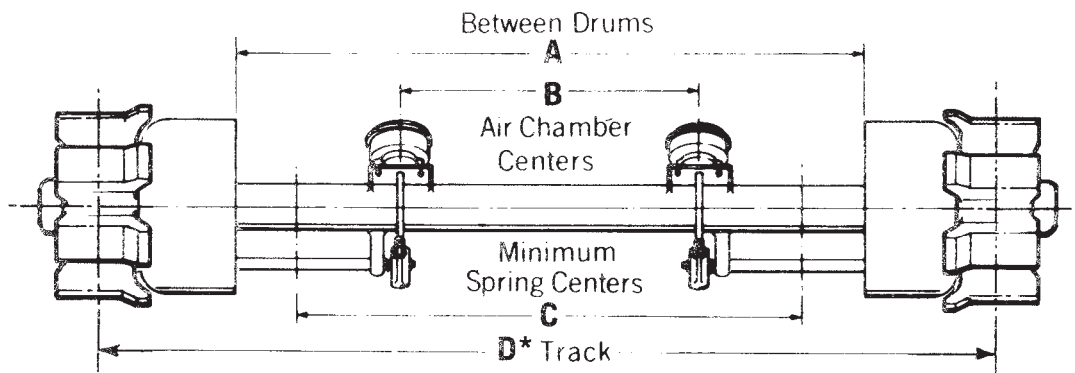

Model No.	Mechanical Air Brake Size	A	B	C	D*	Tire Size	Rim Size	Width Incl. Tires	Camshaft Length
S65	No Brake	—	—	48	100	16 x 25	25 - 11.25	138¾"	26½"
S65	20 x 8	63¾"	23	48	100	18 x 25	25 - 13	143"	

Note: Specify Brake Size and Hub Type when ordering axle assemblies.
* Other Track Widths and Camshaft Lengths are available on request.



S65 SERIES AXLE

75,000 POUND CAPACITY

Brake Size	Hub Type	Wheel Part No.	Brake Shoe Part No.	Brake Block FMS No.	Brake Drum Part No.
20 x 8	Steel Spoke Wheel	KB-6432	KB-6501	4350	7U-20-3

Contact factory for parts list for dual cam brake axle. Furnish model number and date of manufacture.
Banded brake drums available. Add 'B' to brake drum part number when ordering.

Description	Part Number	Description	Part Number
Axle Beam (specify track)	C-11025	Camshaft Housing Grease Fitting	9803
Air Chamber Type 50 Roto.	13904	Grease Retainer	E-11026
Air Chamber Bracket	KB-5155-E	Grease Retainer Ring	E-11027
Air Chamber Bracket Washer	E-11168	Hub Cap	KB-5979
Anchor	KB-6502-1	Hub Cap Gasket	E-10135
Anchor Pin	E-11046	Hub Cap Bolt	14006
Anchor Pin Lock	13305	Hub Cap Lockwasher	11004
Anchor Pin Grease Fitting	9801	Slack Adjuster	14308
Anchor Bolt	14011	Spindle Nut	KB-5631
Anchor Bolt Lockwasher	11005	Spindle D Washer	E-9519
Anchor Bolt Nut	11247	Spindle Nut Locking Bolt	2304
Brake Shoe Bushing	E-11051	Spindle Nut Locking Nut	11280
Brake Shoe Roller	E-11219	Spindle Nut Locking Washer	11008
Brake Shoe Roller Pin	E-11220	Wheel and Drum Attaching Bolt	2306
Brake Shoe Roller Pin Lock	E-10231	Wheel and Drum Attaching Nut	E-11215
Brake Return Spring	D-8689	1" Hardened Washer	15821
Brake Block Bolt	14026	Wheel Studs	15403
Brake Block Bolt Lockwasher	11004	Wheel Rim Clamp	8304
Brake Block Bolt Nut	11265	Wheel Clamp Nuts	11201
Camshaft Washer	E-11221	Wedge Band for 16 x 25 Tires	16002
Camshaft Seal	E-11226	Spacer Band for 16 x 25 Tires	14611
Camshaft Spring	E-11222	Wedge Band for 18 x 25 Tires	16637
Camshaft Retaining Washer	E-11223	Spacer Band for 18 x 25 Tires	14605
Camshaft Retaining Bolt	14025		
Camshaft Lockwasher	11004		

STANDARD PRODUCTION 1 $\frac{3}{4}$ " DIAMETER CAMSHAFTS AND HOUSINGS

Camshaft Number	Overall Length	Housing Number
P-6497 B – P-6498 B	24 $\frac{1}{4}$ "	D-11225-2
P-6499 B – P-6500 B	26 $\frac{1}{2}$ "	D-11225-3
P-6508 B – P-6509 B	29 $\frac{1}{2}$ "	D-11225-5

SPECIAL LENGTH CAMSHAFTS AVAILABLE AT EXTRA CHARGE.

Note: Furnish axle model or serial number when ordering replacement parts.

REPLACEMENT PARTS

K-B Axle Co.

5775 NW WAGON WAY / HILLSBORO, OR 97124-8531 / ph: 866.531.0600 / fx: 503.531.0601

Brake Shoe



Type B

Brake Shoe Part No.	Type	Brake Size	Bushing Part No.	Roller Part No.	Pin Part No.	FMS No.
KB-6501	B	20 x 8	E-11051	E-11219	E-11220	4350-D

Anchor, Brake



Type B

Anchor Part No.	Type	Axle Dia.	Brake Size	Camshaft Dia.	Camshaft Housing Assy. No.
KB-6502	B	6"	20	1/4	D-11225
KB-6502-1	B	6 1/2"	20	1/4	D-11225

Spindle Nut and Washer

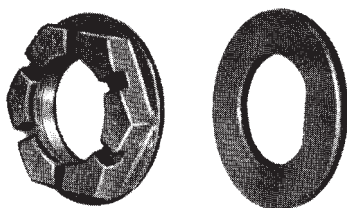

SPINDLE NUT			Axle Series Model No.	WASHER		
Part No.	I.D.	Thrds. Per In.		Part No.	I.D.	O.D.
KB-3987	3	12	T37	E-4450	3/16	4 1/2
KB-5463	3	12	S54	D-5164	3/16	5 1/2
KB-5631	4	12	S55, S65	E-9519	4/8	5 1/2

Anchor Pin, Brake Shoe

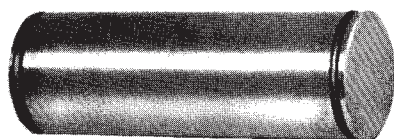

Part No.	Type	O.D.	Length
E-11046	Straight	1 1/2	6 1/8



REPLACEMENT PARTS

Spring, Camshaft



Part No.	Length	I.D.
E-11222	1¼	1 ¹⁹ / ₁₆

Return Spring, Brake Shoe

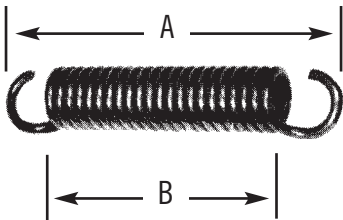

Part No.	A	B	Diameter
D-8689	6⅞	4½	1⅞

Roller and Pin, Brake Shoe

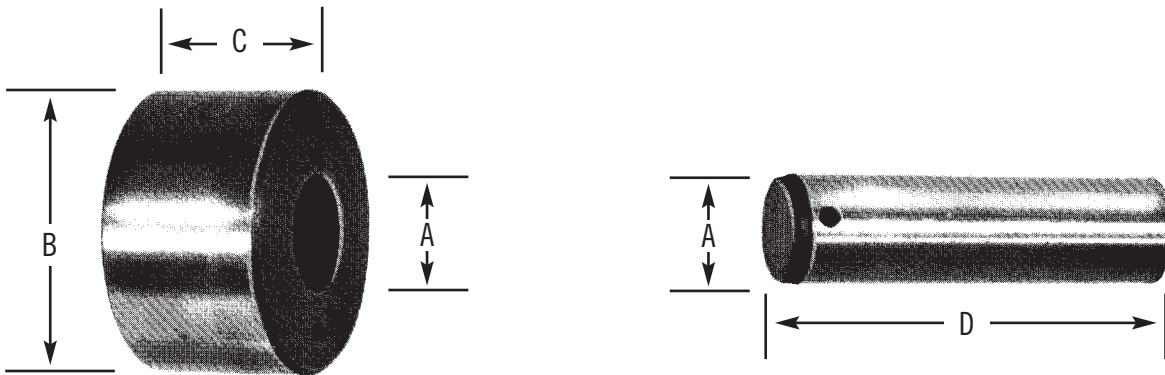

Roller Part No.	Pin Part No.	A	B	C	D
E-11219	E-11220	⅞	1⅞	1	2¼

Bushings

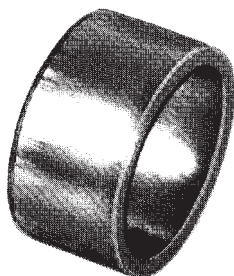

Part No.	I.D.	O.D.	Length
E-11051	1½	1¾	1½

REPLACEMENT PARTS

K-B Axle Co.

5775 NW WAGON WAY / HILLSBORO, OR 97124-8531 / ph: 866.531.0600 / fx: 503.531.0601

Camshaft and Camshaft Housing

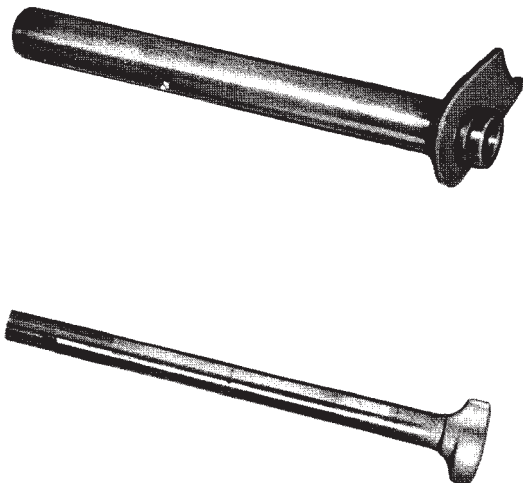

Housing Ass'y. Part Number *	Overall Length	Camshaft Ass'y. Part Number **	Overall Length	Diameter
FOR 6" & 6½" AXLE WITH 20" BRAKES, KB-6503 CAM BRACKET				
D-11225-1	17½	P6495-96	22½	1¾
D-11225-2	18½	P-6497-98	24¼	1¾
D-11225-3	21½	P-6499-6500	26½	1¾
D-11225-4	22½	P-6517-18	27½	1¾
D-11225-5	24¼	P-6508-09	29½	1¾
D-11225-6	23½	P-6527-28	28¾	1¾
D-11225-7	21½	P-6532-33	27¼	1¾
D-11225-8	22½	P-6538-39	28½	1¾
D-11225-9	21½	P-6540-41	26¾	1¾
D-11225-10	27½	P-11241-11-12	32¾	1¾
D-11225-11	9¾	P-11241-15-16	14½	1¾
D-11225-12	25½	C-11241-17-18	30¾	1¾

*1¾" diameter housing assembly uses E-11226 O-ring and #11221 washer.

**1¾" diameter camshaft assembly uses E-11223 retaining washer and ¾ x 7/8 N.F. screw with lock washer.

Hub Cap and Hub Cap Gasket

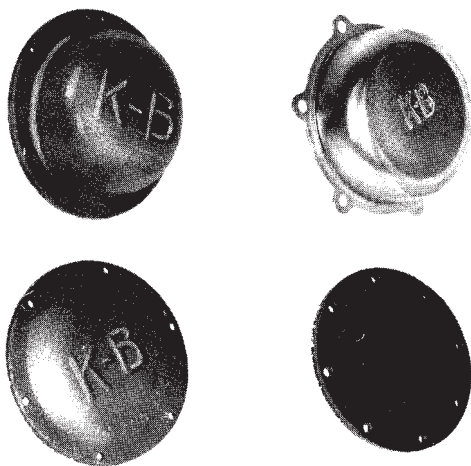

HUB CAP		For Axle Model No.	Gasket Part No.	Number of Holes	Hole Size	Bolt Centers
Part Number	Type					
D-8025	B-Pressed Steel	T37	E-8661	6	1½	6¾
KB-3976	C-Casting	S54	D-5747	6	1¾	9¼
KB-5979	A-Casting	S55	E-10135	6	1¾	8½

Grease Retainer and Ring



Retainer Part No.	For Axle Model No.	I.D.	O.D.	Width	Ring Part No.	I.D.	O.D.
E-10708	T37	4¾	7½	1	E-7642	7¼	7¼
E-11066	S54	4½	8½	1	E-7704	7¾	8½
E-10893	S55	5	8½	1	E-7704	7¾	8½
E-11026	S65	5¼	9¼	¾	E-11027	8¾	9¼



REPLACEMENT PARTS

Bracket, Air Chamber

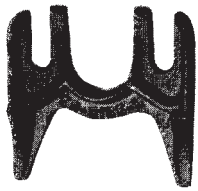

A



B

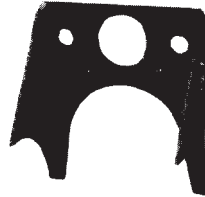

C

Part No.	Type	Axle Diameter
KB-5155-E	A	6"
KB-6417-2	B	6"
C-11602	C	6½"

Air Chambers

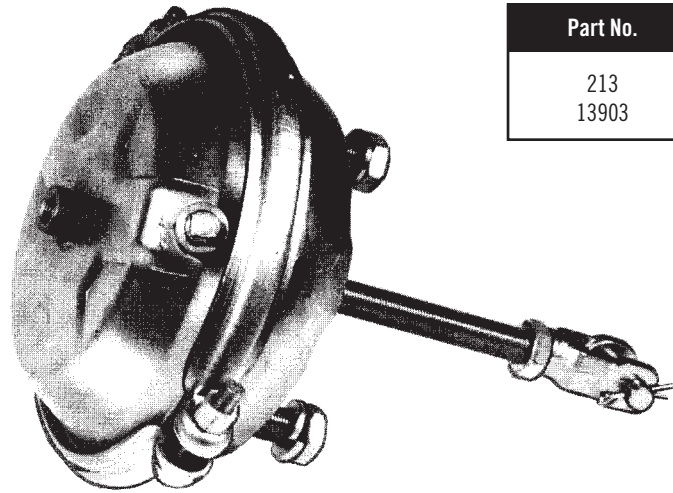

Part No.	Type
213	36
13903	36

Slack Adjusters

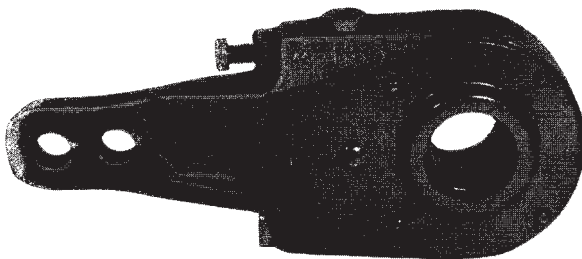

Part No.	Description	First Hole	Second Hole
14308	Type PL 35 1¼" S.A.E. 10 spline	8"	6¾"

REPLACEMENT PARTS

K-B Axle Co.

5775 NW WAGON WAY / HILLSBORO, OR 97124-8531 / ph: 866.531.0600 / fx: 503.531.0601

Hubs

Used on 40,000 lb. Capacity Axles

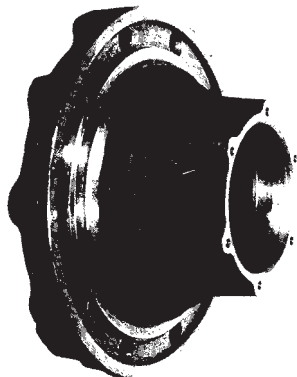

Part No.	Bolts	Circle	BEARING CUP		Stud Size
			Outer	Inner	
KB-5944	10	13 ³ / ₁₆ "	742	854	1"*

For T37 Series Axles

Used on 60,000 lb. Capacity Axles

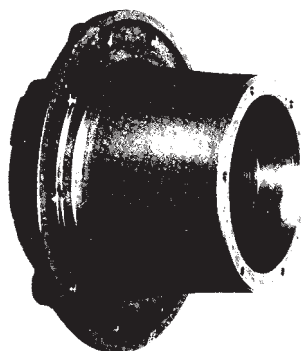

Part No.	Bolts	Circle	BEARING CUP		Stud Size
			Outer	Inner	
KB-5947-1	10	13 ³ / ₁₆ "	854	932	1"*

For S55 Series Axles

Used on 75,000 lb. Capacity Axles

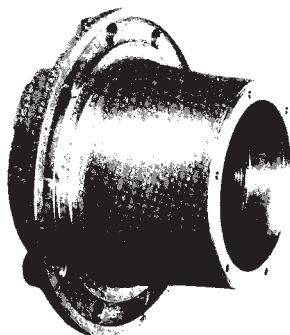

Part No.	Bolts	Circle	BEARING CUP		Stud Size
			Outer	Inner	
KB-6424	12	15"	67322	95925	1"*

For S65 Series Axles

* 1" diameter is on hub end, not wheel end.



REPLACEMENT PARTS

Spoke Wheels

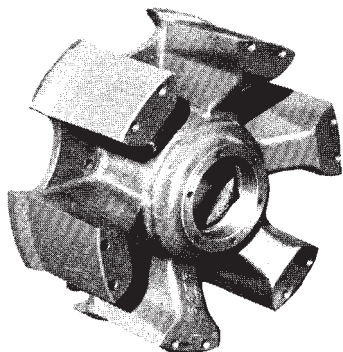

Used on 40,000 lb. Capacity Axles

Part No.	BEARING CUP	
	Outer	Inner
KB-6475	742	854

For T37 Series Axles

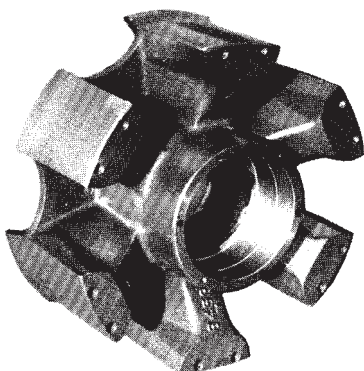

Used on 60,000 lb. Capacity Axles

Part No.	BEARING CUP	
	Outer	Inner
KB-6453	932	932

For S54 Series Axles

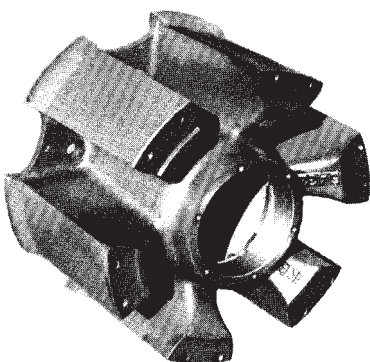

Used on 75,000 lb. Capacity Axles

Part No.	BEARING CUP	
	Outer	Inner
KB-6432	67322	95925

For S65 Series Axles

REPLACEMENT PARTS

K-B Axle Co.

5775 NW WAGON WAY / HILLSBORO, OR 97124-8531 / ph: 866.531.0600 / fx: 503.531.0601

Disc Wheel and Rim Holding Components

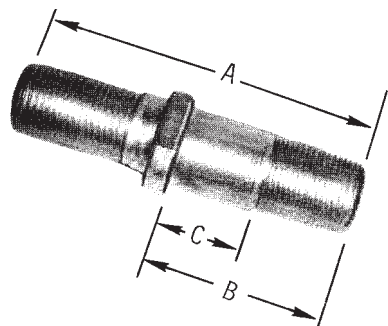

Heavy Duty Studs for Dual Wheels 1" – 14 Threads on Hub End

Wheel End	KB Part No.		Budd Part No.		A Dim.	B Dim.	C Dim.
	R.H.	L.H.	R.H.	L.H.			
15/16"	15435	15436	49541	49542	5"	27/8"	1 13/32"
15/16"	15442	15443	63341	63342	5 5/8"	3 1/2"	1 25/32"
15/16"	15438	15439	63114	63115	4 1/2"	2 1/4"	25/32"

All Studs are 1" on Hub End

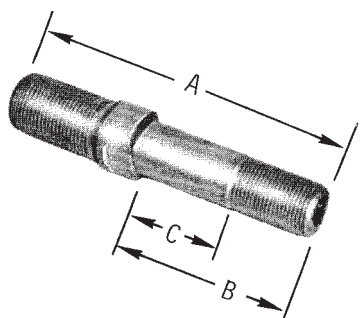

Heavy Duty Studs for Single Wheels 1" – 14 Threads on Hub End

Wheel End	KB Part No.		Budd Part No.		A Dim.	B Dim.	C Dim.
	R.H.	L.H.	R.H.	L.H.			
1 1/16"	15431*	15432	48146	48147	6 7/32"	3 1/2"	1 29/32"
1 1/16"	15433*	15434	48151	48152	5 13/32"	2 11/16"	3 1/32"
1 1/16"	D-10798R	D-10798L			6 7/16"	3 3/8"	2 1/4"
1 1/16"	D-10989R	D-10989L			5"	2 3/16"	1 5/16"

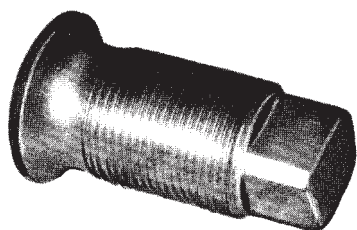

Inner Cap Nut – Heavy Duty

KB Part No.		Budd Part No.		Inner Thread	Outer Thread	Square Flats
R.H.	L.H.	R.H.	L.H.			
11236	11237	49414	49415	1 5/16"-12	1 5/16"-12	1 5/16"

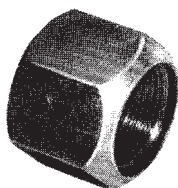

Outer Cap Nuts – Heavy Duty

KB Part No.		Budd Part No.		Inner Thread	Hex Dia.
R.H.	L.H.	R.H.	L.H.		
11234	11235	48051	48052	1 3/16"-12	1 3/4"
11238	11239	49416	49417	1 5/16"-12	1 3/4"



Rim Clamps

KB Part No.	Goodyear No.
8304	CL771
8305	CL1008

* 1 1/16" wheel end



Rim Clamp Nuts

KB Part No.	Goodyear No.
11201	NU30

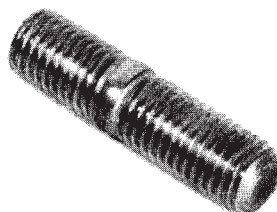

Rim Clamp Studs

KB Part No.	Goodyear No.
12904	ST570
15401	ST29
15403	ST770
15459	ST70



REPLACEMENT PARTS

Brake Drums



Part No.	Brake Face Dia.	Outside Dia.	Overall Depth	Pilot Dia. For Hub	B.C.	Bolt No.	Hole Size	Brake Face Width
6U-20-8	20	22¼	10¼	10%	13⅜	6	13/16	8¼
6U-20-9	20	22¼	10¼	9/16	13⅜	10	1/32	8¼
7U-20-1	20	22¼	12½	10%	13⅜	10	1/32	8½
7U-20-3	20	22¼	12½	10%	13⅜	6	1/32	8½

Spacer Bands

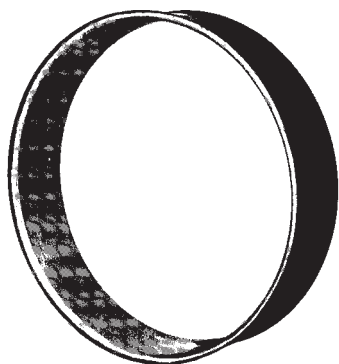

Part No.	Width	Inside Dia.
C-11140	5½"	22.469"
14605	7¾"	21.500"
14610	6⅝"	21.500"
14611	6½"	21.500"

Extra Strength Spacer Bands Available

Wedge Bands



Part No.	Width	Inside Dia.
16001	3⅜"	22.375"
16002	3⅜"	21.375"
16637	2⅝"	21.375"

MISCELLANEOUS HARDWARE *K-B Axle Co.*

5775 NW WAGON WAY / HILLSBORO, OR 97124-8531 / ph: 866.531.0600 / fx: 503.531.0601

Cap Screws



Part No.	Size
2304	¼" x 5½" Hex, NC
2305	1" x 3"
2306	1" x 2½" Hex, NF, HT
14006	¾" x 1" NC
14011	¾" x 3" NF
14013	¾" x 2½" NF, HT
14015	¾" x ¾" NC
14017	¾" x 2¾" NF
14025	¾" x 7/8" NF
14034	½" x 1¼" NC
14042	1" x 2¾" NF, gd.5
14060	1" x 2" NF, HT

Flat Washer



Part No.	Size
15821	1"

Set Screws



Part No.	Size
14037	¾" x 1¼" NF
14045	½" x 1½"

Lock Rings



Part No.	Size
13305	1½"
13306	2"

Locknuts

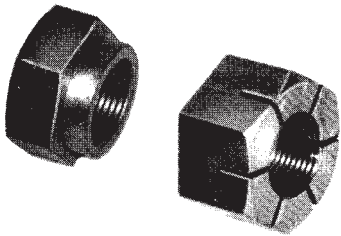

Part No.	Size
E-11215	1"

Grease Fittings

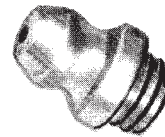

Part No.	Description
9801	30°
9803	straight
9805	90°

Lockwashers

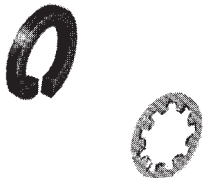

Part No.	Size
11004 A	¾" med.
11005 A	¾"
11006 A	¾" med.
11007 A	1" med.
11008 A	¼"
11011 A	½"
15842 B	½"
15844 B	¾"

Spring Pins

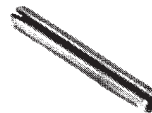

Part No.	Size
E-10231	¼" x 1¾"

Hex Nuts



Part No.	Size
11247	¾" NF
11255	¾" NC
11260	¾" Back, NF
11265	¾"
11279 Jam	½"
11280	¼"
11281 Jam	¾"

CSK Brass Bolt

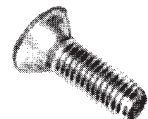

Part No.	Size
14026	¾" x 1¼"

Cotter Pins



Part No.	Size
8903	¼" x 4"

TIRE INFORMATION GUIDE



5775 NW WAGON WAY / HILLSBORO, OR 97124-8531 / ph: 866.531.0600 / fx: 503.531.0601

Model	Beam Capacity	Brake Size	Wheel or Hub Type	Rim Size	Tire Size	Tire O.D.	Loaded Radius
Wheels accepting demountable rims preferred for axle capacities of 40,000 lbs. and over.							
T-37	40,000	20 x 8	10 stud 13 ³ / ₁₆ B.C.	H 8.50-24 8.50-25	P 12.00-24 P 12.00-25	49.6	23.3
T-37	40,000	20 x 8	Wheel for Dual Demountable Rims	S 8.50-24 8.50-25	P 12.00-24 P 12.00-25	49.6	23.3
S-54	60,000	20 x 8	Wheel for Dual Demountable Rims	S 10.00-24 10.00-25	P 14.00-24 P 14.00-25	54.0	25.1
S-55	60,000	20 x 8	10 stud 13 ³ / ₁₆ B.C.	H 10.00-24 10.00-25	P 14.00-24 P 14.00-25	54.0	25.1
S-65	75,000	20 x 8	12 stud 15 B.C.	H 11.25-25 13.00-25	P 16.00-25 P 18.00-25	57.2 63.8	26.3 29.2
S-65	75,000	20 x 8	Wheel for Dual Demountable Rims	S 11.00-25 13.00-25	P 16.00-25 P 18.00-25	57.2 63.8	26.3 29.2
S-65	75,000	20 x 8	12 stud and single Fabricated Wheel	H 25.00-29	29.5-29	77.4	35.1
S-65	75,000	20 x 8	12 stud and single Fabricated Wheel	H 22.00-33	27.00-33	88.7*	40.0*

*This information varies with tire selected.

Tire and rim manufacturer's data must be verified for each application. Specifications are nominal only.

H=Hub S=Spoke Wheel P=Preferred Applications

AXLE INFORMATION FORM



5775 NW WAGON WAY / HILLSBORO, OR 97124-8531 / ph: 866.531.0600 / fx: 503.531.0601

Quantity Required _____

Load Per Axle _____ Pounds Maximum Speed _____

Track Required _____ Overall Width With Tires _____ Between Tires _____

Tire Size _____ Duals _____ Singles _____ Rim Size _____

Brake Size _____ Ambient Temperature _____ Other _____

Hub Type _____ Stud _____ Bolt Circle _____

Stud Size: _____ Alternate: Spoke Wheel Type _____

Suspension to be Used _____ Model _____ Tandem _____ Single _____

Mounting Centers _____

Road Conditions: Good _____ Medium _____ Poor _____ On Highway _____ Off Highway _____

Braking Requirements: Severe _____ Average _____ Light _____

SET UP REQUIRED:

Camshafts: Length _____ Air Chambers: Type _____ Chamber Centers: _____

(All are non-cambered)

APPLICATION DATA:

NOTE: PLEASE ADVISE IF ANY DIMENSIONS ARE CRITICAL TO FIT IN YOUR APPLICATION/MOUNTING SPACE.

SUMMARY OF LIMITED WARRANTY

Automotive products of our manufacture are guaranteed against defective materials and workmanship when under normal use and service for twelve (12) months from shipment. The responsibility of K-B Axle Company under this warranty is limited to replacing any part or parts found defective which must be shipped to our plant for inspection (freight prepaid) after which an adjustment determination will be made. **RESTRICTION:** The application of the products presented in this catalog are restricted to normal commercial use and must be applied and installed by competent, experienced personnel.

Axles are manufactured of heat treated steel, necessitating strict heat and welding control.

For a full version of our warranty, visit our website at www.k-baxle.com or contact us to have a copy mailed to you.

Items listed in this catalog are not always in stock. Please check expected availability with our sales department.

ALL SPECIFICATIONS ARE SUBJECT TO CHANGE WITHOUT NOTICE.

DIMENSIONS ARE IN INCHES
TOLERANCES ON:
FRACTIONS ANGLES DECIMALS
± 1/64 ± 1/2° ± .010
ALL DIAMETERS CONCENTRIC
(UNLESS NOTED OTHERWISE)

DRAWN BY
CHECKED
DESIGN ENG
PROJECT ENG
RELIABILITY
PRODUCTION

K-B Axle
LOS ANGELES, CALIFORNIA
TITLE
5160-41AP
LAYOUT

24.00-35T TIRE

$26\frac{5}{16}$

$5\frac{3}{16}$

17

$10\frac{5}{16}$

$3\frac{1}{2}$

$10\frac{7}{8}$

$6\frac{3}{4}$

$3\frac{3}{4}$

$5\frac{7}{16}$

$7\frac{1}{4}$

$7\frac{3}{8}$

SEE
DOUBLE
SIZE &
LAYOUT

10 SHOE

5

$13\frac{3}{8}$

$7\frac{5}{8}$

$4\frac{1}{8}$

$5\frac{3}{4}$

$1\frac{1}{16}$

421437

$1\frac{1}{2}$

$3\frac{5}{8}$

420801

$1\frac{1}{2}$

C-11577

$23\frac{29}{32}$ PRESS UP



126 TR

$8\frac{29}{32}$

K-BAXLE.COM

$143\frac{13}{16}$