

S65 SERIES AXLE

75,000 POUND CAPACITY

K-B Axle Co.

5775 NW WAGON WAY / HILLSBORO, OR 97124-8531 / ph: 866.531.0600 / fx: 503.531.0601

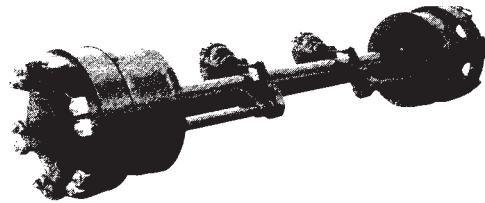

Approx. WT. 2690 lbs.

AXLE BEAM 6½" O.D. Solid Steel
Heat-treated 4140

BEARINGS	Cone	Cup
Inner	95525	95925
Outer	67390	67322

HUBS Steel spoke wheels for dual demountable 16 x 25 or 18 x 25 tires.
12 stud, 15" B.C. hubs also available.

BRAKES 20" x 8" x ¾" FMS 4350 – Other brake sizes available for special application. Contact factory indicating requirements.

FEATURES

- ▶ Completely enclosed camshafts seal dirt out and grease in.
- ▶ Individual, positively locked brake shoe anchor pins for positive, permanent alignment.
- ▶ Brake shoes are of all-steel construction with replaceable bushings.
- ▶ Wheels engineered to meet the most severe operating conditions.

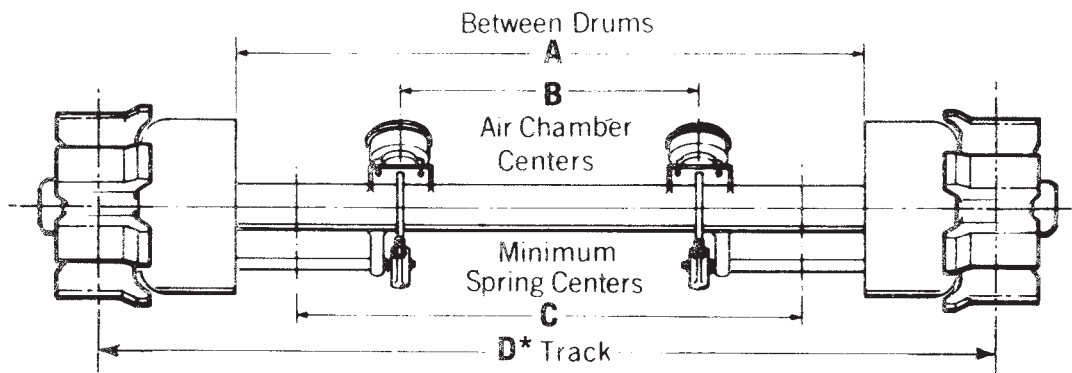

Model No.	Mechanical Air Brake Size	A	B	C	D*	Tire Size	Rim Size	Width Incl. Tires	Camshaft Length
S65	No Brake	—	—	48	100	16 x 25	25 - 11.25	138¾"	26½"
S65	20 x 8	63¾"	23"	48	100	18 x 25	25 - 13	143"	

Note: Specify Brake Size and Hub Type when ordering axle assemblies.
* Other Track Widths and Camshaft Lengths are available on request.



S65 SERIES AXLE

75,000 POUND CAPACITY

Brake Size	Hub Type	Wheel Part No.	Brake Shoe Part No.	Brake Block FMS No.	Brake Drum Part No.
20 x 8	Steel Spoke Wheel	KB-6432	KB-6501	4350	7U-20-3

Contact factory for parts list for dual cam brake axle. Furnish model number and date of manufacture.
Banded brake drums available. Add 'B' to brake drum part number when ordering.

Description	Part Number	Description	Part Number
Axle Beam (specify track)	C-11025	Camshaft Housing Grease Fitting	9803
Air Chamber Type 50 Roto.	13904	Grease Retainer	E-11026
Air Chamber Bracket	KB-5155-E	Grease Retainer Ring	E-11027
Air Chamber Bracket Washer	E-11168	Hub Cap	KB-5979
Anchor	KB-6502-1	Hub Cap Gasket	E-10135
Anchor Pin	E-11046	Hub Cap Bolt	14006
Anchor Pin Lock	13305	Hub Cap Lockwasher	11004
Anchor Pin Grease Fitting	9801	Slack Adjuster	14308
Anchor Bolt	14011	Spindle Nut	KB-5631
Anchor Bolt Lockwasher	11005	Spindle D Washer	E-9519
Anchor Bolt Nut	11247	Spindle Nut Locking Bolt	2304
Brake Shoe Bushing	E-11051	Spindle Nut Locking Nut	11280
Brake Shoe Roller	E-11219	Spindle Nut Locking Washer	11008
Brake Shoe Roller Pin	E-11220	Wheel and Drum Attaching Bolt	2306
Brake Shoe Roller Pin Lock	E-10231	Wheel and Drum Attaching Nut	E-11215
Brake Return Spring	D-8689	1" Hardened Washer	15821
Brake Block Bolt	14026	Wheel Studs	15403
Brake Block Bolt Lockwasher	11004	Wheel Rim Clamp	8304
Brake Block Bolt Nut	11265	Wheel Clamp Nuts	11201
Camshaft Washer	E-11221	Wedge Band for 16 x 25 Tires	16002
Camshaft Seal	E-11226	Spacer Band for 16 x 25 Tires	14611
Camshaft Spring	E-11222	Wedge Band for 18 x 25 Tires	16637
Camshaft Retaining Washer	E-11223	Spacer Band for 18 x 25 Tires	14605
Camshaft Retaining Bolt	14025		
Camshaft Lockwasher	11004		

STANDARD PRODUCTION 1³/₄" DIAMETER CAMSHAFTS AND HOUSINGS

Camshaft Number	Overall Length	Housing Number
P-6497 B – P-6498 B	24 ¹ / ₄ "	D-11225-2
P-6499 B – P-6500 B	26 ¹ / ₂ "	D-11225-3
P-6508 B – P-6509 B	29 ¹ / ₂ "	D-11225-5

SPECIAL LENGTH CAMSHAFTS AVAILABLE AT EXTRA CHARGE.

Note: Furnish axle model or serial number when ordering replacement parts.